

ACURA SPA SYSTEMS, INC.

MEGATROL™ SERIES-220

MODEL:	MT60DP2B1S1	
240V	60A. Service	60 Hz
REVISION:	29/08/07	* Optional Items

Heater: H5 = 5.5kW; H4 = 4kW.

WARNING: MUST BE WIRED PER NATIONAL ELECTRIC CODE AND ALL LOCAL CODES AND REGULATIONS.

NOTE: To supply 120V to the heater, move RED wire on load side of **Terminal Block** from RED (L2) to WHITE (N).

NOTE: To supply 120V to the pump, move BLUE wire on load side of **Terminal Block** from RED (L2) to WHITE (N).

WARNING: CONNECT ONLY TO A G.F.C.I. PROTECTED CIRCUIT.

Side Connectors

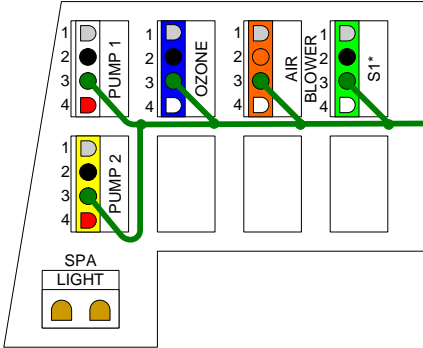

MT60DP2H5B1S1	
MT = Megatrol Series	
60	= 60 Amp Service; 45 Amp Rated
DP2	= Dual Pumps, 240V
H5	= Single Heater, 5.5kW
B1	= Blower, 120V
S1	= Receptacle, 120V

Indicator Lights Connections

A	→ 120V Power	[L1,N]
B	→ 240V Power	[L1,L2]
C	→ Low Pump	[4,1]
D	→ High Pump	[2,1]
E*	→ Pump 2	[4,1]
F*	→	
G*	→	
H*	→ Blower	[2,1]
I	→ Heater 1	
J*	→	

* Optional Items

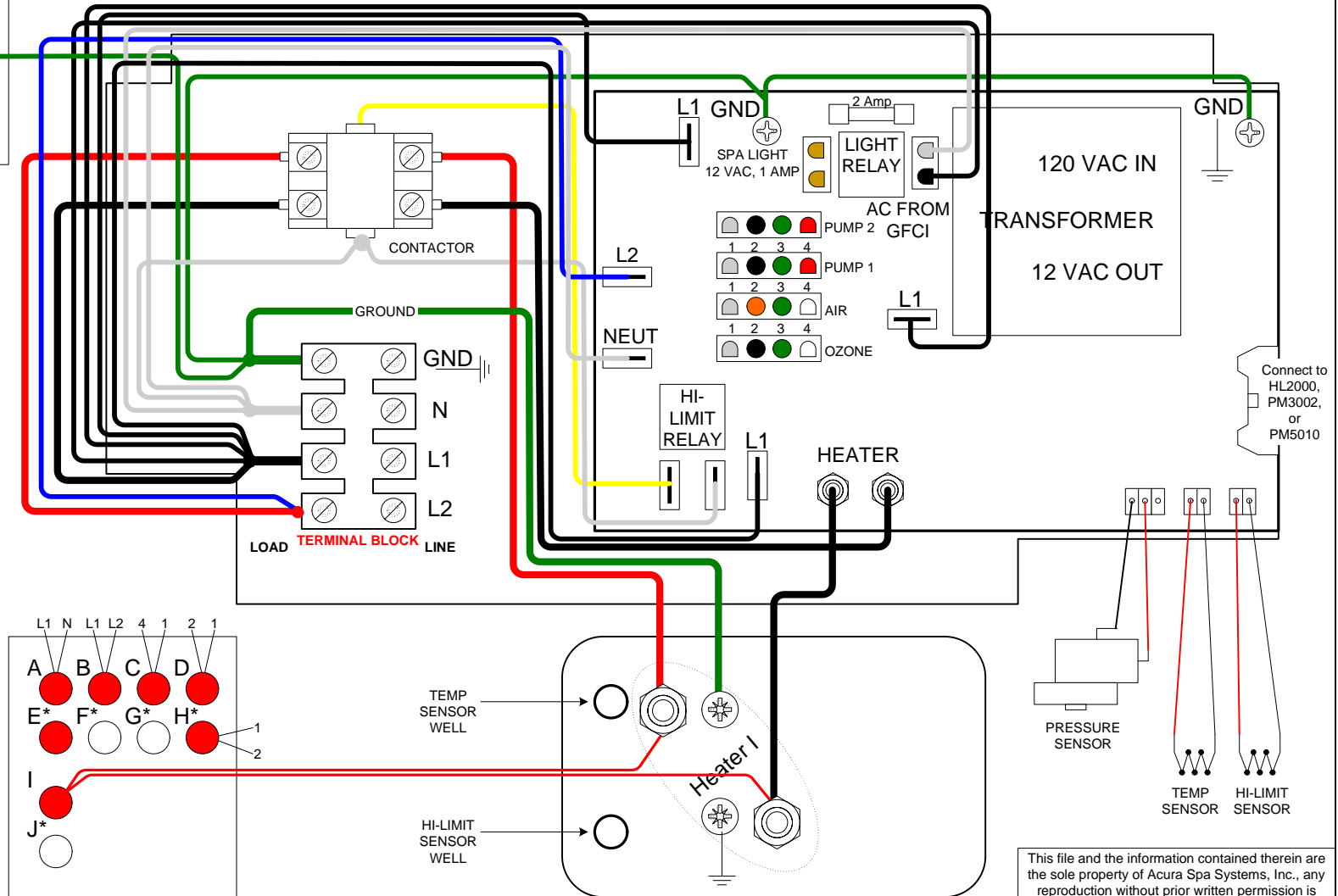

This file and the information contained therein are the sole property of Acura Spa Systems, Inc., any reproduction without prior written permission is strictly forbidden.